

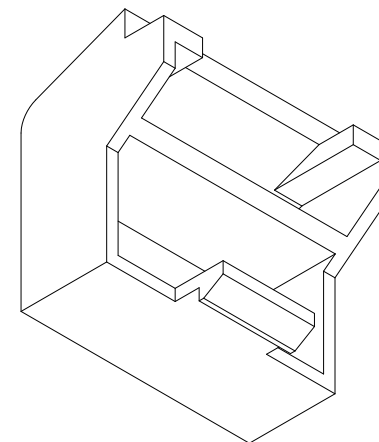

慈溪市万捷电子有限公司

CIXI WANJIE ELECTRONIC CO., LTD

产品规格书
THE SPEC SHEET

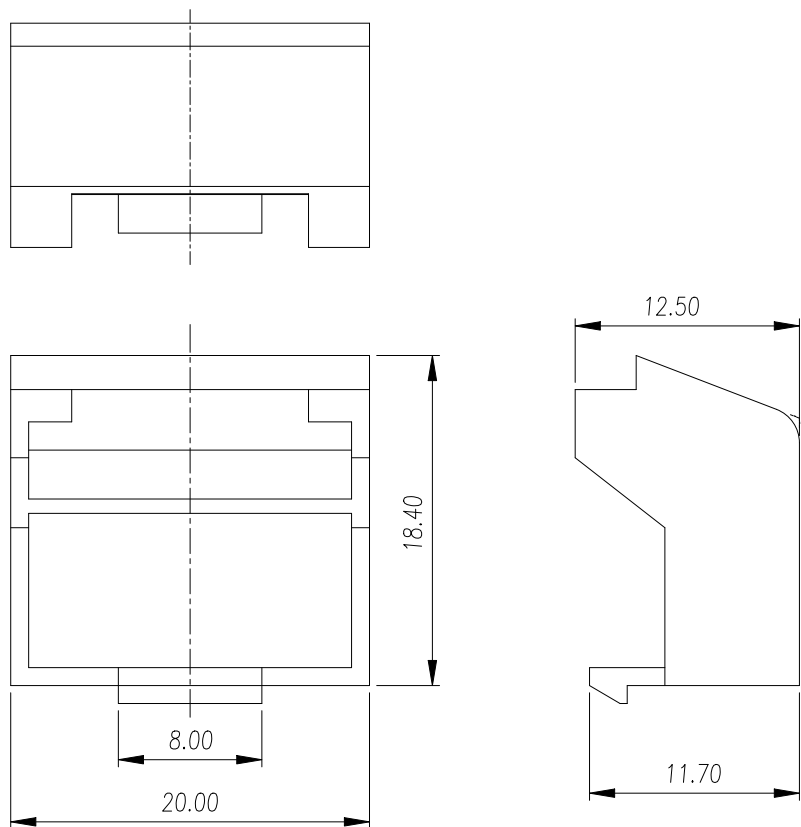

塑件/Housing

PA66, UL94V-0

linear dimension (Tolerances Standard GB/T 14486-2008)

linear dimension (Tolerances Standard GB/T 14486-2008)								—		
variable range	to 6	over 6 to 10	over 10 to 30	over 30 to 60	over 60 to 100	over 100 to 160	over 160 to	to 10	over 10 to 100	over 100 to
tolerance	±0.20	±0.30	±0.50	±0.70	±1.00	±1.30	±1.60	0.10	0.30	0.60

单位 / UNITS	mm	尺寸 / SIZE	A4	比例 / SCALE	1:1	第三视角 / THIRD ANGLE PROJECTION	
						名称 / TITLE	FMDT-04P-14-FCG
慈溪市万捷电子有限公司 CIXI WANJIE ELECTRONIC CO., LTD							